

Section: Division of Nursing
Approval: _____

PROCEDURE

Index: 7420.001a
Page: 1 of 8
Issue Date: March 30, 2005

HACKETTSTOWN REGIONAL MEDICAL CENTER

Originator: O. Lopez, RN BSN CNOR
Reviewed by: W. Zeiher, RN

OR
(Scope)

TITLE: THE ANDREWS SPINAL SURGERY FRAME

PURPOSE: To instruct the OR Nurse on the proper use of the Andrews Spinal Surgery Frame.

Content:

A. Identification of Basic Frame Components

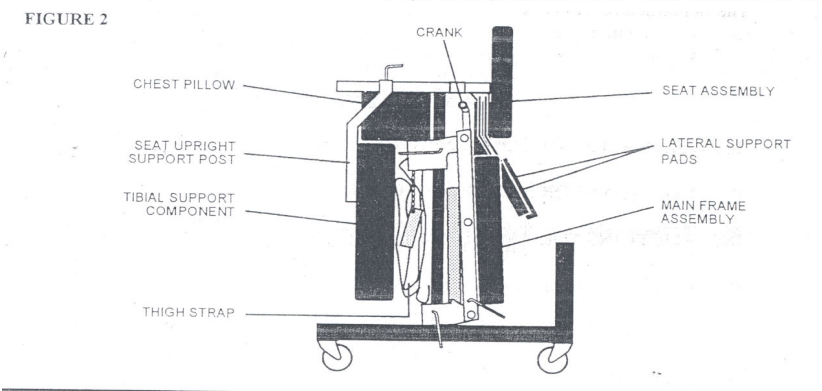
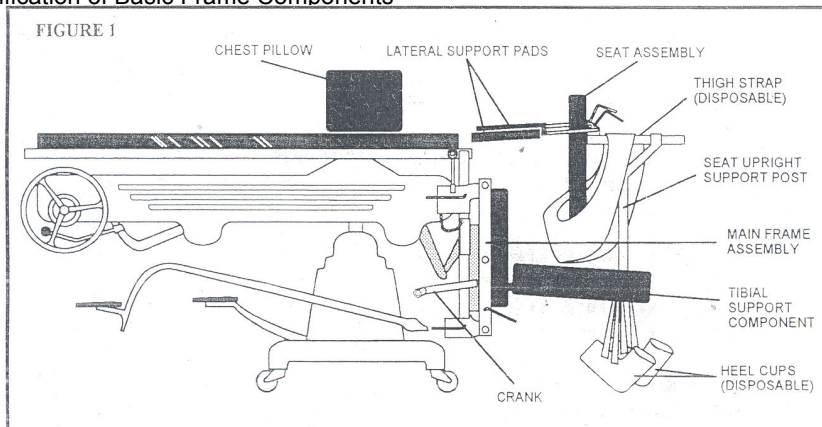

B. Instructions for the AMSCO and Skytron Operating Table

1. Preparation of the AMSCO and Skytron Table
 - a. Raise the foot end until it is "level" with the whole table, (i.e., parallel to the floor).
 - b. Remove padding and cassette tunnels from the entire table.
 - c. Replace padding on the head and center section of table.
 - d. Remove any side rail sockets from the foot end.
2. Loosen all four clamp handles on the main frame assembly (counter-clockwise rotation), as far as possible without applying undue pressure.

3. Hold the main frame section as shown in Figure 3a and slide the clamps over the side rails until the limit bar contacts the end of the table. Be certain all four clamps are over the side rails.

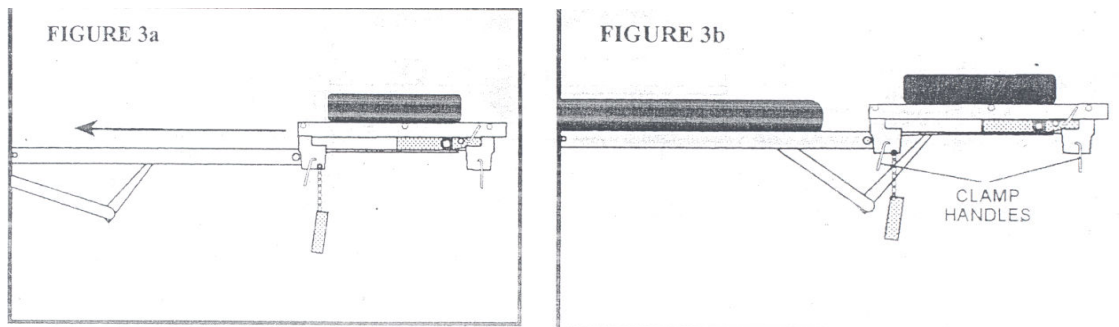

4. Tighten each of the four clamp handles securely (clockwise rotation). Check each handle for tightness.

WARNING! Failure to tighten handles may result in the patient dropping.

5. The main frame safety device is connected by a short length of chain. Place it over the side rail and position it as far forward as possible. Tighten the thumbscrew to lock it in this position. The main frame safety device in its proper position will help stop the main frame from disengaging from foot end of OR table.

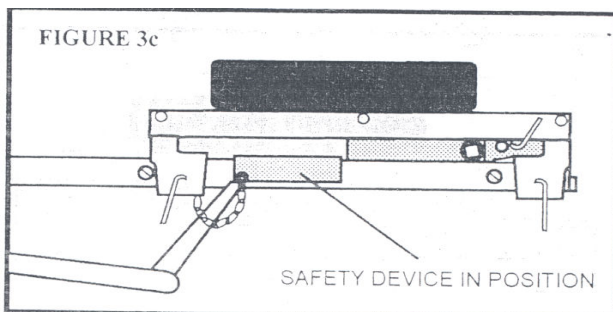

C. Patient Transfer and Positioning

1. Wrap the patient's legs with compression devices.

WARNING! When wrapping the lower extremities with compression devices, make certain that there is not binding or constriction at the popliteal fossa.

2. The patient is rolled onto the table in a prone position with the knees coming to rest midway on the padded portion of the main frame section.

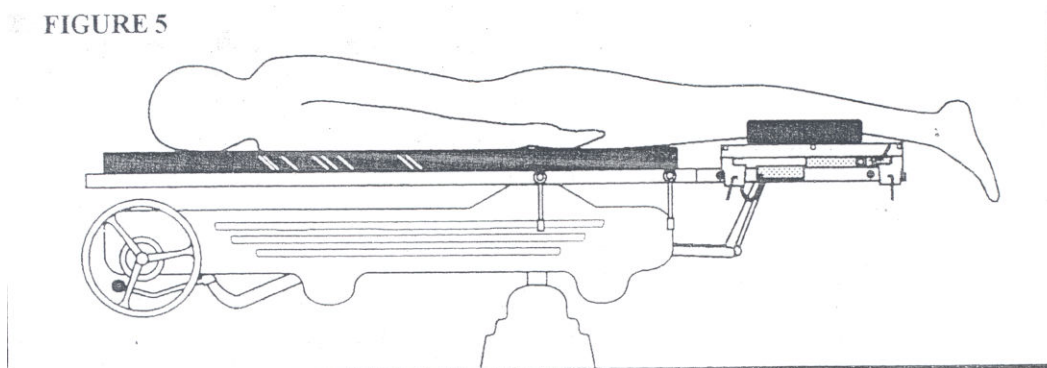

3. Hold the knees in a 90° flexed position and insert the two-pronged tibial support component into the mounting holes on the main frame section.

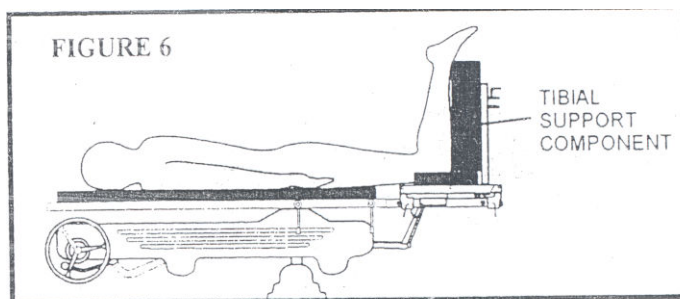

4. The safety lock is a lever operated detent pin. Depress the lever all the way when installing or removing the tibial support component.

WARNING! Be certain that the tibial support component is ALL the way into the frame and the lever has returned to its original seated position before using the frame.

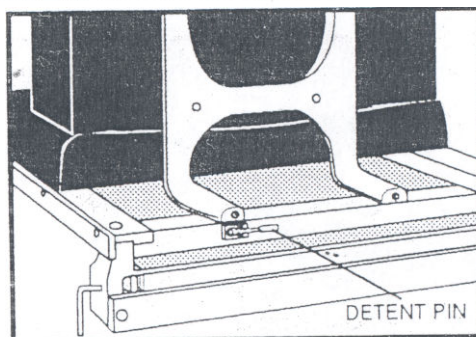

DETENT PIN

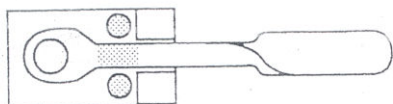

To remove, press the detent pin releasing the lock and continue pulling the tibial support all the way out.

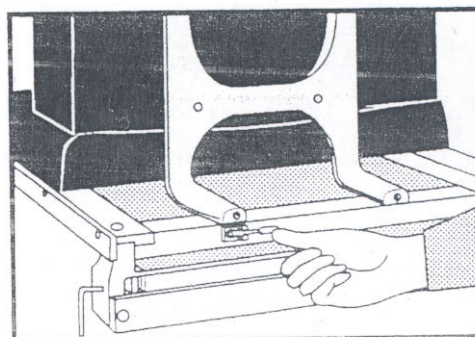

5. Spread the knees until they are symmetrically positioned approximately two inches from the edge of the tibial support pad. Attach the heel cups to the patient's feet and fasten them through the buckles on the underside of the pad. Pull the fastening straps firmly so the entire length of the tibiae bear weight on the pad, making a small impression.

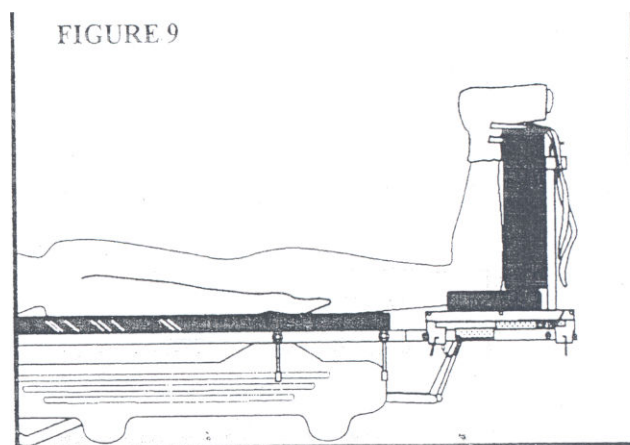

- Pivot the lateral support pads back from the seat and lock in position. Install the seat support bar all the way into the upright post. Note that the offset in the upright post is positioned away from the seat. Install the seat and upright support assembly into the receptacle on the tibial support component. Position the center of the seat pad in line with the patient's hips and secure the locking handle (clockwise rotation).

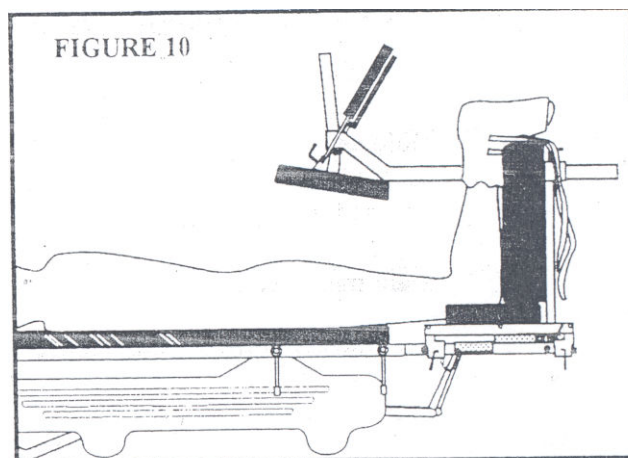

- Lower the seat pad until it is approximately half way between the patient and its highest position, then lock the handle securely.

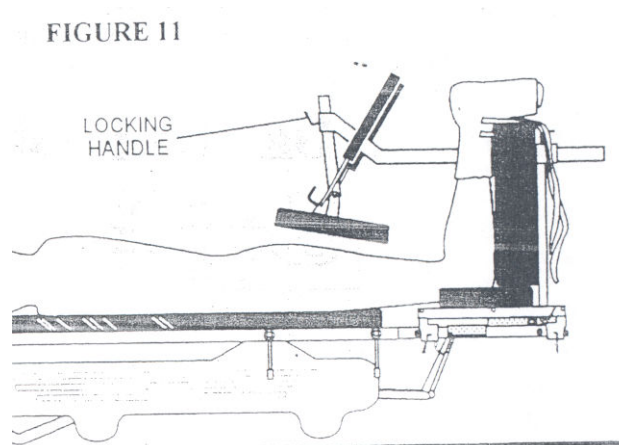

- Flex the foot end of the table at the patient's hips until they are 90° to the upper torso.
NOTE: As the table is being flexed, the patient should be assisted back so that the gluteal area contacts the seat.

Adjust the seat support bar until the angle between the femur and the tibia is approximately 80° to 85° .

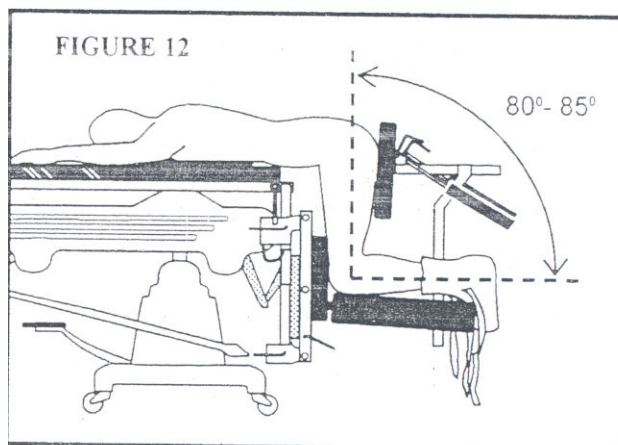

9. Loosen the thigh support pads and position them laterally along both thighs until the patient is stable. Lock in this position.

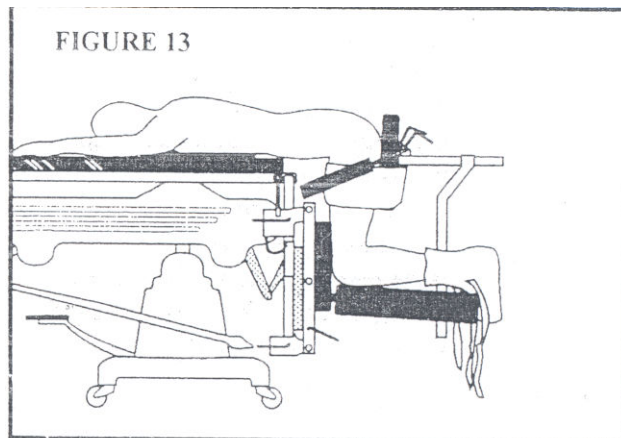

10. Wrap the thigh strap around the patient and the seat assembly to maintain the patient's contact with the seat.

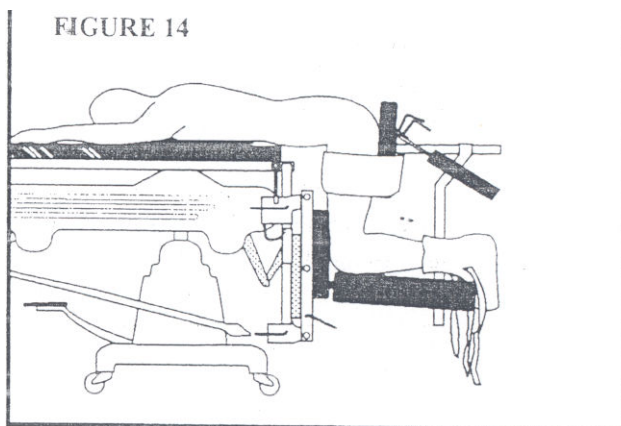

11. Attach the crank handle to the rod on the main frame section. Turn the crank clockwise to elevate the patient until the abdomen, in a completely dependent position, is clear of the table.
12. Place the chest pillow under the patient's sternum directly between the shoulders. The patient's arms should be supported by armboards.

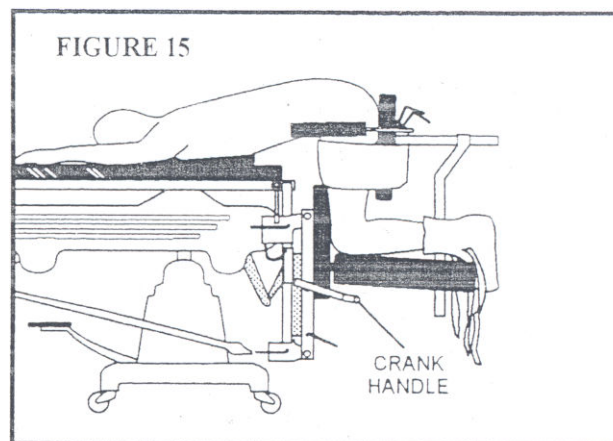

WARNING! In dealing with anesthetized, extremely obese patients, it is not uncommon to produce a state of shock when these patients are placed in a prone position due to compression of the vena cava. Therefore, it is extremely important to avoid placement of the chest pillow at or on the abdominal areas as this may cause hypotension due to vena cava compression.

WARNING! Improper positioning of the chest on the chest pillow must be avoided. If the chest pillow is too inferior, it could compress the diaphragm. If it is too superior, it could obstruct the airway, interfering with breathing. Pressure should be distributed evenly over the sternum. In the case of large patients, additional padding and/or the OSI Wiltse Chest Jack™ (Model No. 5315) may be necessary.

WARNING! In case of obesity or anticipated lengthy procedures, flex the hips to no greater than 80 degrees when in the prone sitting position.

WARNING! Verify that there is no binding or constriction in the popliteal fossa, especially after flexion of the hips and knees.

13. Grasp the patient's ankle and gently slide the leg away from the Thigh Pad until no more than half an inch of space is created between the knee and the Thigh Pad. Apply gentle traction toward the toes, until the tibia's weight bears on the pad, make a small impression in the foam. Tighten the heel cup straps in position.

WARNING! Failure to transfer the load off the knees to the pretibial area or applying excessive loads to the pretibial area may result in a pressure concentration on the skin leading to pressure sores.

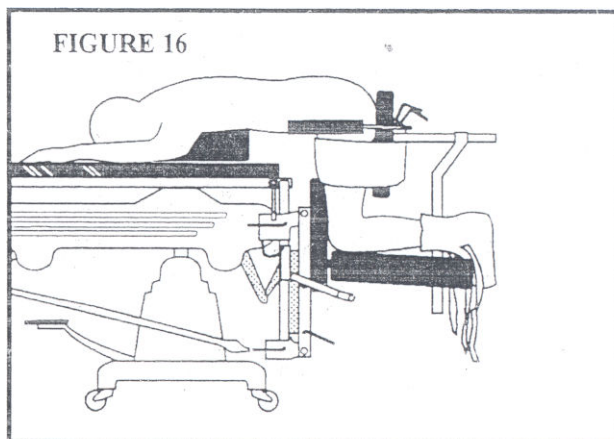

14. With the Patient now securely positioned, adjust the operating table into a reverse Trendelenburg position so that the patient's back assumes a horizontal position.

WARNING! The neck should be neutral or slightly flexed to avoid undue stress. The shoulder joints should be slightly abducted and slight extended. The elbow joints should be flexed to approximately 90 degrees to avoid traction on the brachial plexus.

NOTE: For proper head, neck and shoulder positioning, we suggest the OSI Model No. 5315 Wiltse Chest Jack and OSI Model No. 1927 Prone Positioning Pillow.

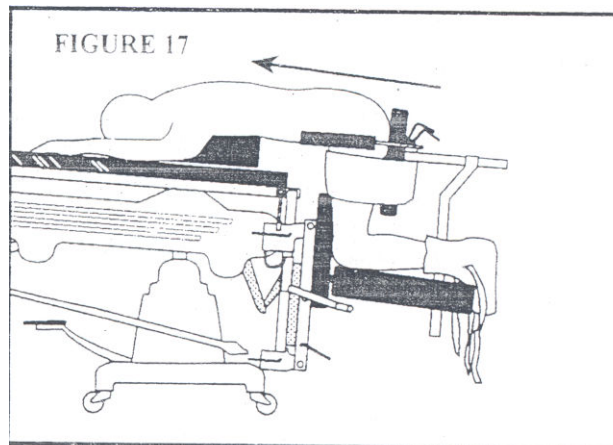

NOTE: The frame is provided with a latch mechanism which engages the gear to hold the tibial support component in the selected position. To lower the tibial support, it is necessary to slightly raise the support with the crank while depressing and holding the latch mechanism with the other hand. Slowly lower the tibial support with the crank. (See Figure 18)

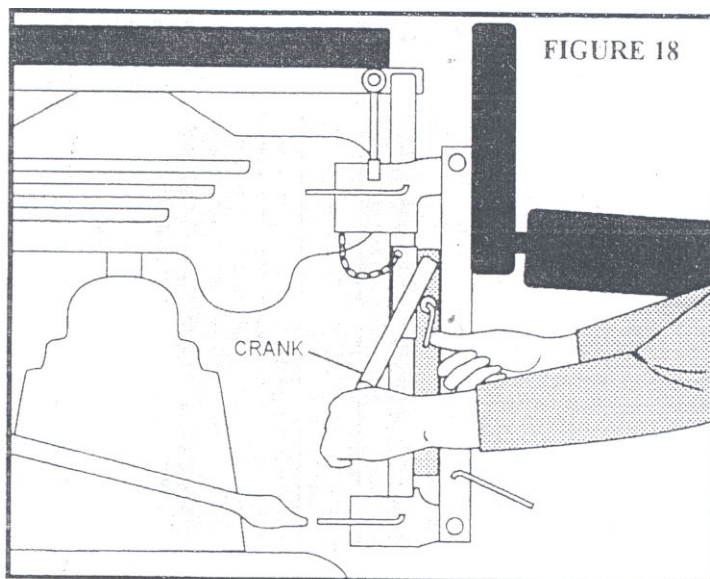

D. Patient Removal

TO REMOVE the patient from the operating position loosen the lateral thigh strap and seat assembly from the tibial support component. Remove the heel cups from the frame, but leave them attached to the patient. Roll the patient off the operating table onto a gurney from this position.

WARNING! Post-operatively if the legs are questionable, the lower extremities should be elevated and compartment pressure should be monitored. Zimmer, Inc. has a simple device on the market for such compartment measurements.

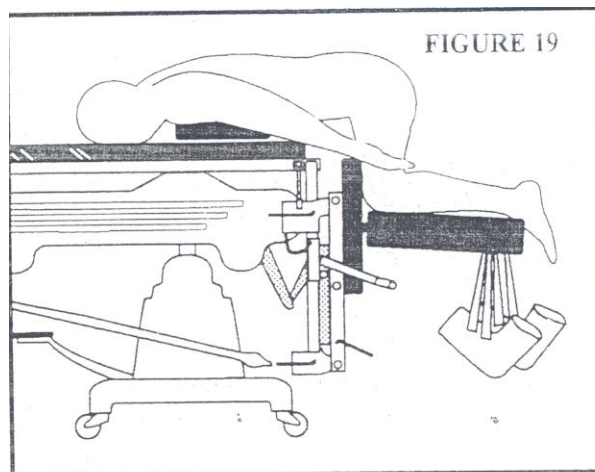

STORAGE: The components of the spinal surgery frame should be replaced on the storage chart as shown in Figure 2 on page 2. A conductive dust cover is provided for the entire cart. (See Figure 2).

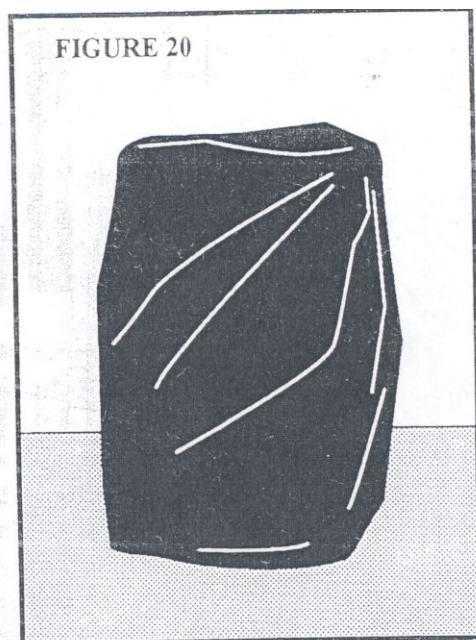

Reference: OSI – The Andrews Spinal Surgery Frame Technique Manual